

The feasibility analysis of a new anchor product by using combined SWOT and analytic hierarchy process

Jun HU^{1,a}, Xiaoling ZHANG^{2,b,*}

¹The College of Post and Telecommunication, Wuhan Institute of Technology, Wuhan, China

²Department of Commercial Technology, Xijing University, Xi'an, China

^adugu5540_2002@163.com, ^bxiaoling0915@126.com

*corresponding author

Keywords: Composite materials, Green design, Slope support, SWOT, Analytic hierarchy process.

Abstract. A new GFRP-WPS panel is proposed, by using the combined SWOT and analytic hierarchy process, the feasibility of this new product is analyzed from both qualitative and quantitative aspects. The limitation of using one single method is solved. The reliability of analysis is strengthened. It is of great significance for grasp the market attributes of this product and enhances its competitiveness.

1. Introduction

Product design is one of the creative activities which can reveal the scientific and technological progress. It can also meet the needs of the community through a certain way. Product design covers a variety of areas of knowledge with a strength planning and purpose.

In recent years, product design has been studied by many researchers from design theory, design methods and other aspects. Deng [1] has summarized the basic theory of product design and technology, he also pointed out that product innovation is the core of industrial innovation and the focus of global economic competition. Liu and Shan [2] divided the product design into three stages, initial, middle and last stages. They established a design analysis method with user experience as the core, and the criterion of usability evaluation in product innovation design was proposed. Fu et al. [3] and Guo et al. [4] pointed out the poor quality of some products, resource consumption and the weakness in international competitiveness, green product design approach was proposed.

The factors of product system design are classified into function, structure, artificial, handsome and environment by Song [5]. The reliability of each factor was also evaluated by using analytical hierarchy process. The existing product design was summarized by Xu [6], he also pointed out that product design has a great influence on the feasibility of product.

The properties of wood-plastic composites were analyzed and summarized by Huang [7] and Yuan [8], the application of wood-plastic composites was studied comprehensively and systematically from the product design perspective. The removable composite panel combined by soil nailing retaining system which was invented by Li and Jia [9] use soil arch to balance the load

of soil. The panel is square and fixed by soil nailing. The locator is used in this product and cannot cover the whole soil, which become the biggest drawback of this product. In raining season, soil become into plastic state, can even flow or break, this product will not be useful any more.

Considering the advantages and disadvantages of composite panel combined by soil nailing supporting system, a new type of supporting product made by soil nailing and wood-plastic panel is proposed. The product design process is introduced and the feasibility of this new product is evaluated by using combined hierarchy analysis and SWOT analysis method.

2. Design of supporting product

2.1 Design of wood-plastic composite panel

Figure 1 shows the shape of wood-plastic composite panel. This panel use hexagon as face shape with width of 500mm to 1000mm and thickness of 15mm to 20mm. One of the panels can be fixed from the centre by soil nail, other panels can be installed around this fixed panel edge to edge. A neat and sealed support face can be formed by this process. These panels can be uninstalled conveniently and reused. This product has many advantages such as light weight, wrap-proof, easy to cut, easy to process and assemble and so on.

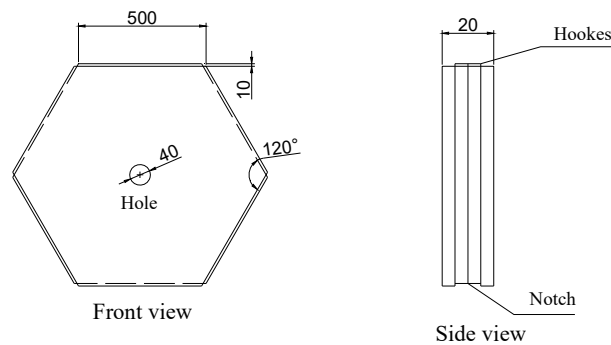

Figure 1 Shape of wood-plastic panel.

2.2 Anchorage of product

Nut is used for anchorage. The head of anchor is made of high strength glass fiber composites. The production technology of this type of composites is mature. This glass fiber composites is energy saving and environmental protection, and it is combined with the body of anchor closely. This anchor has advantages such as easy to install and remove, easy to adjust and fix panel well. In practical application, hole will be made on panel, soil nail will be passed through the panel, and the panel will be fixed. Panels are pre-assembled on paper according to the position of soil nails in order to determine the number of panels and determine the assembly sequence. Panels can be fixed on soil nails in sequence. This process makes the adjustment and subsequent construction much easier.

For poor soil condition such as stream-plastic soils, one slab can be used to connect two soil nails. This slab can enhance the stability of the panels by crossing the composite panels. Slab length is 200mm beyond the soil nail spacing at each end. The layout of the slabs is shown in Figure 2. These slabs can also be replaced by reinforcement mesh.

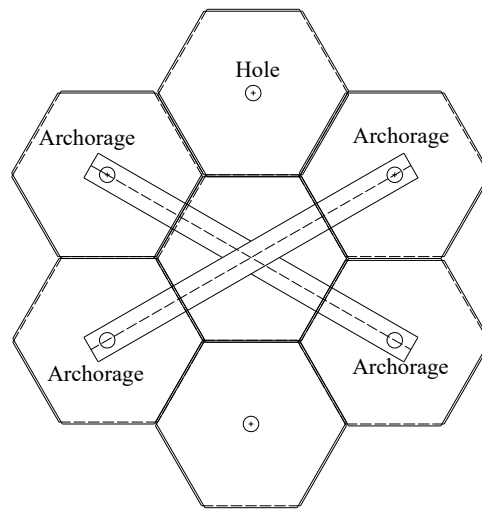

Figure 2 Layout of slabs.

Actual construction environment is complex and changing, slope angles also vary. Soil nail angle is usually down in the soil in a certain range (about $10^{\circ} \sim 15^{\circ}$), therefore, this cause the pad and the panel cannot fit closely. Cement can be poured into the gap between the pad and panel and enhance the stability of this system. The anchorage of panel by soil nail can be shown in Figure 3.

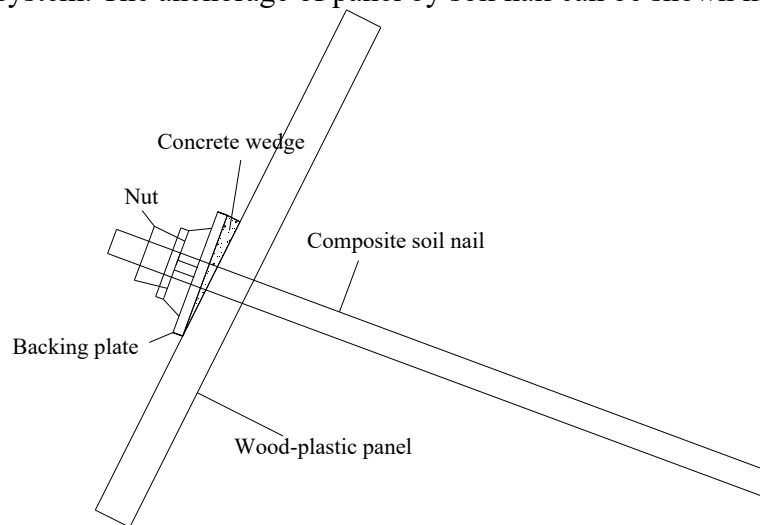

Figure 3 Anchorage of panel by using soil nails.

2.3 Construction technology of product

After the soil nails are installed, holes are made on the panel according to the diameter of the soil nail. Then panels are hung on the face of slope. The other panels are installed slot to slot hook and locked by waterproof glue. All the panels are locked together and waterproof. Figure 4 shows the process of assembly.

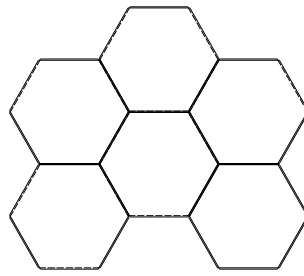

Figure 4 The process of assembly.

2.4 The recyclability of product

The design of recyclability is the core part of the green product design. It not only requires product functionality, appearance and cost control, but also need to focus on recycling at the end of the product life cycle. The design of recyclability contains general design principles, economic consequences and environmental impact analysis and the structural design of reusable and removable.

An excellent product structural design simplifies the recovery process, reduces recovery costs and rationalizes the use of resources. Product recycling process can be summarized as the following steps. Firstly, remove the waste products and sort after the end of its useful life. Second, recycling of the waste product includes analysis, renovation and remodeling. Thirdly, reuse the products which have passed the inspection test. The difficulty demolition work on products is the most important and critical part in product recyclability design.

A new type of anchorage is used in this manuscript, anchor head is made of high-strength glass fiber composites, it is linked closely together with nails and easy to install and remove. Hexagonal panels made of composites are used. There is no gap between any two panels. The mosaic effect is excellent. The panels can also be uninstalled conveniently. Overall, this anchoring product has strong recyclability, less pollution to the environment and is sustainable.

3. The feasibility analysis of anchoring product by using modified SWOT analytical hierarchy process

3.1 Steps of the application of modified SWOT analytical hierarchy process

Analytical hierarchy process (AHP) is a qualitative and quantitative approach for decision making. AHP is based on objects, guidelines and programs et al. In SWOT analysis, S means 'Strengths', W means 'Weaknesses', O means 'Opportunity' and T means 'Threats'. S and W are internal factors, O and T are external factors. Hu [10] and Han [11] approved that combined analytical hierarchy process and SWOT analysis has advantages in enterprise competition analysis.

The combined analytical hierarchy process and SWOT analysis is used in this manuscript for the feasibility analysis of anchor product. Based on the sequence of the weight of each factor level, eigenvector method is used to enhance the reliability of the feasibility analysis. Better results for decision makers can be supplied. The specific steps are as follows:

First, set up the AHP analysis model (as shown in Figure 5). Factors are classified based on the existed information. SWOT table is made and the AHP model is set up based on the relationship within and between factor levels. In the standard analytic hierarchy process requires factors within the group should not be too much, three most critical factors are selected in this manuscript.

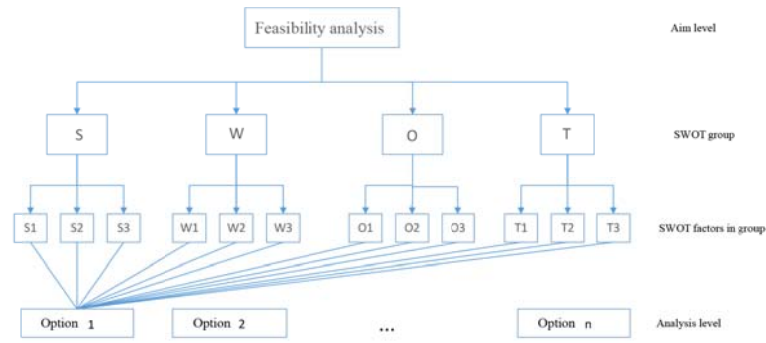

Figure 5 AHP analysis model.

Second, set up weight matrix and calculate weight of each factor. The weight of each factor is calculated by using eigen roots method. Then the weight vector of each factor is accounted for by using the normalization method. In order to ensure the objectivity and fairness of weighting process at the same time, avoid personal bias and the influence of single factor caused by accidental errors, industry experts and professionals scoring method is used for comprehensive evaluation. The score of each factor is calculated by using proportional scaling method. Using scores 1, 2, 3, ... , 9 to weight each factor.

Third, set up weight matrix and calculate the weight of each factor between groups, then sequence all the factors within one group by priority. The level of factors between groups is higher than the level of factors within group, but in the analysis process, the factors within group should be taken into account first. This is reverse analysis method. Factors within group are analyzed first, than typical factors can be selected. The priority of factors between groups is calculated after weight matrix built.

Forth, SWOT analytic hierarchy process results are used in strategy design and the feasibility analysis. In order to ensure the reasonability of the final weight of each factor, the consistency of all weight matrices should be tested, the procedure is as follows:

First, calculate the maximum characteristic root λ_{\max} by equation

$$(A - \lambda_{\max} I)q = 0 \quad (1)$$

The consistency index CI is solved by

$$CI = \frac{\lambda_{\max} - n}{n - 1} \quad (2)$$

If $CI=0$, weight matrix is totally consistent. The larger the CI is, the worse the consistence is.

$$CR = CI/RI \quad (3)$$

RI is the random index.

If $CR \leq 10\%$, the weight matrix passed the consistency test, otherwise failed.

3.2 The feasibility analysis of anchor product

The SWOT analytic hierarchy process is used for the feasibility analysis of the new anchor product proposed in this manuscript. Firstly, set up the analysis model. Table 1 shows the factors of this new anchor product. The AHP analysis model is shown in Figure 5. Secondly, set up the judgment matrix. Weights of factors within each group and between groups are calculated. The judgment matrices of each group are shown in Tables 2-6. Sort the factors within each group according to the weights, than sort all the factors in all groups. At the same time, the CR values are calculated within each group and between groups. The final result is shown in Table 7.

Table 1 SWOT analysis of anchor product

<p>Strengths (S) S1 recyclable, high rate of reusing S2 environmental friendly S3 good design and innovation</p>	<p>Opportunities(O) O1 potential opportunity in the market O2 new materials or procedure used O3 support from the government</p>
<p>Weaknesses(W) W1 unreliable W2 no advantages for market competition W3no advantages in product quality</p>	<p>Threats(T) T1 crucial competition in the market T2 low interests T3 similar products</p>

Table 2 judgment matrix of Group S

Group S	S1	S2	S3
S1	1	0.2	2
S2	5	1	6
S3	0.5	0.1667	1

Table 3 judgment matrix of Group W

Group W	W1	W2	W3
W1	1	3	5
W2	0.3333	1	2
W3	0.2	0.5	1

Table 4 judgment matrix of Group T

Group T	T1	T2	T3
T1	1	0.5	1
T2	2	1	4
T3	1	0.25	1

Table 5 judgment matrix of Group O

Group O	O1	O2	O3
O1	1	4	7
O2	0.25	1	3
O3	0.1429	0.3333	1

Table 6 SWOT group judgment matrix

	S	W	O	T
S	1	5	3	7
W	0.2	1	0.25	2
O	0.3333	4	1	3
T	0.1429	0.5	0.3333	1

Table 7 weight of each factor

SWOTgroup	CR (group)	priority	SWOT factors	RI	CR	Priority within group	Priority in all groups	
Group S	0.0455	0.5747	recyclable, high rate of reusing	0.0146	0.0280	0.1721	0.0989	
			environmental friendly			0.7258	0.4171	
			good design and innovation			0.1020	0.0586	
Group W		0.1010	0.0028	unreliable	0.0035	0.0035	0.6483	0.0654
				no advantages for market competition			0.2296	0.0232
				no advantages in product quality			0.1220	0.0123
Group O		0.2539	0.0162	potential opportunity in the market	0.0312	0.0312	0.7049	0.1790
				new materials or procedure used			0.2109	0.0535
				support from the government			0.0841	0.0214
Group T		0.0705	0.0268	crucial competition in the market	0.0516	0.0516	0.2318	0.0163
	low interests			0.5842			0.0412	
	similar products			0.1840			0.0130	

Table 7 shows that all the judgment matrices passed the consistence test. The maximum consistency ratio is 5.2%, it is smaller than 10%. The strength group and the opportunity group have advantages than weakness group and threat group. This new anchor product has advantages respect to other products, it has potential to be accepted by the market. This new anchor product is also environmental friendly and potential opportunity in the market. The shortcomings of this product are low interests and not much application in real projects.

4. Conclusions

A new anchor product made of composite soil nail and wood-plastic panel is proposed. The outlook, anchorage and construction procedure are introduced. SWOT analytic hierarchy has been used to do the feasibility analysis for this new product. By using combined SWOT and hierarchy analytic method, the feasibility of this new product is evaluated from both quantity and quality. This new product has advantages than traditional anchor product in recyclability and environmental protection. Also the new SWOT analytic hierarchy method can be used by others for new products evaluation.

References

- [1] Jiati Deng. Essential design theory and technology for product development[J]. China Mechanical Engineering, 2000, Z1: 139-143. (in Chinese)
- [2] Heshan Liu. Study on the Design Method of Product Usability of Typical Technology[D]. Shandong University, 2014. (in Chinese)
- [3] Zhihong Fu, Yucheng Pen. The green design method of product[J]. Mechanical Design and Research, 2000, 02: 10-12+6. (in Chinese)
- [4] Weixiang Guo. Research on Process and Method of Conceptual Design for Green Product[D]. HeFei University of Technology, 2006. (in Chinese)

- [5] Yun Song. The feasibility analysis of product design based on Analytic Hierarchy Process[J]. Industrial design, 2011, 12: 102+104. (in Chinese)
- [6] Bin Xu, Ge Huang. Construction design influence in product shape and feasibility[J]. PACKING ENGINEERING, 2005, 06: 222-223. (in Chinese)
- [7] Xiao Huang. Research of the Application of Wood Plastic Composites in Industrial Product Design[D]. Nanchang University, 2011. (in Chinese)
- [8] Nijuan Yuan. The Product Design Method and Application for Wood-Plastic composites[D]. Shaanxi University of Science and Technology, 2012. (in Chinese)
- [9] Zhigang Li, Hong Jia, Siqing Qin, Ping Ma, Haitao Qian. Mechanical characters of composite material soil-nail and numerical analysis[J]. Rock and Soil Mechanics, 2005, 12: 1953-1953+1962. (in Chinese)
- [10] Qun Hu, Wenyun Liu. Improvement and Case Analysis of SWOT Method Based on Analytic Hierarchy Process[J]. Information Theory and Practice, 2009, 03: 68-71. (in Chinese)
- [11] Xiaojing Han. Application of Analytic Hierarchy Process in SWOT Analysis[J]. Information retrieval, 2006, 05: 119-122. (in Chinese)